

per cavità
for cavity **3A**

"EV22"

BOBINA : ED 100%
COIL : ED 100%

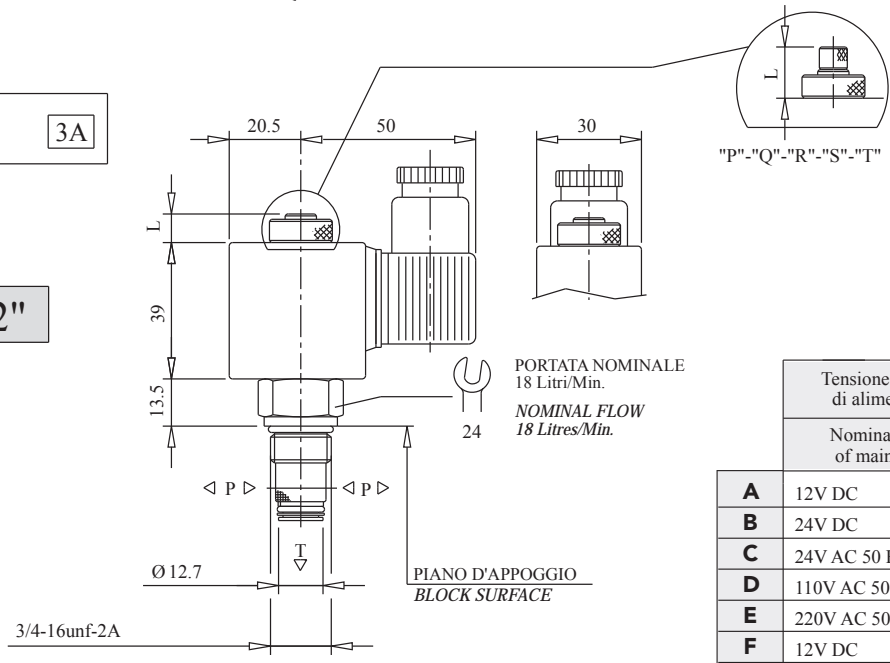

PORTATA NOMINALE
18 Litri/Min.
NOMINAL FLOW
18 Litres/Min.

PIANO D'APPOGGIO
BLOCK SURFACE

	Tensione Nominale di alimentazione	SIMBOLO	L
	Nominal Voltage of main tension	SYMBOL	
A	12V DC		7
B	24V DC		
C	24V AC 50 Hz		
D	110V AC 50 Hz		
E	220V AC 50 Hz		
F	12V DC		12
G	24V DC		
L	24V AC 50/60 Hz		
M	110V AC 50/60 Hz		
N	220V AC 50/60 Hz		
P	12V DC		15
Q	24V DC		
R	24V AC 50 Hz		
S	110V AC 50 Hz		
T	220V AC 50 Hz		

CODICE ORDINAZIONE
ORDERING CODE

1

CODICE ORDINAZIONE
ORDERING CODE

2

BOBINA: classe d'isolamento a norme VDE 0580
Protezione a norme DIN 40050
IP65 (con connettore montato)
Per ulteriori informazioni vedere catalogo valvole oleodinamiche

COIL: insulation class see norm VDE 0580
Protection degree see norm DIN 40050
IP65 (with connector mounted)
See hydraulic valves catalogue for more information

per cavità
for cavity **3A**

"EV40"

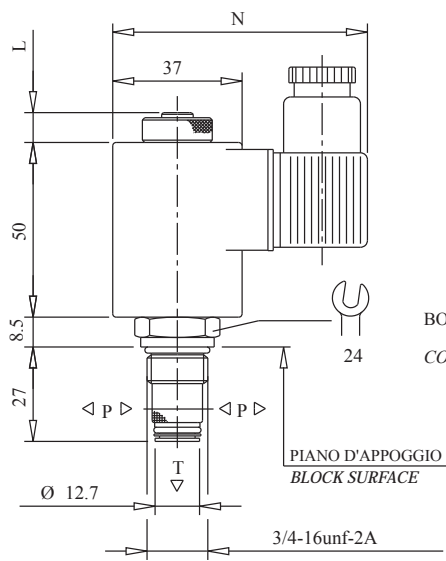

BOBINA : ED 100%
COIL : ED 100%

PORTATA NOMINALE
37 Litri/Min.
NOMINAL FLOW
37 Litres/Min.

	Tensione Nominale di alimentazione	SIMBOLO	N	L
	Nominal Voltage of main tension	SYMBOL		
A	12V DC		72.5	6.5
B	24V DC			
C	24V AC 50/60 Hz			
D	110V AC 50/60 Hz			
E	220V AC 50/60 Hz			
F	12V DC		85	12
G	24V DC			
L	24V AC 50/60 Hz			
M	110V AC 50/60 Hz			
N	220V AC 50/60 Hz			

BLOCCHETTO BASE

BASE BLOCK

Schema oleodinamico
Hydraulic circuit

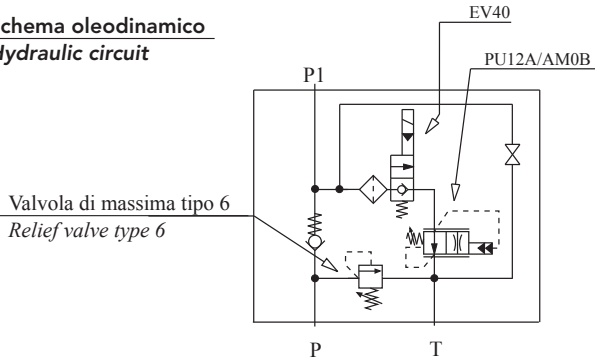

Codice ordinazione
Ordering code

S 1 5 1 - N 1 7 8

Nota: valvola elettrica EV40 tipo 2
Note: solenoid valve EV40 type 2

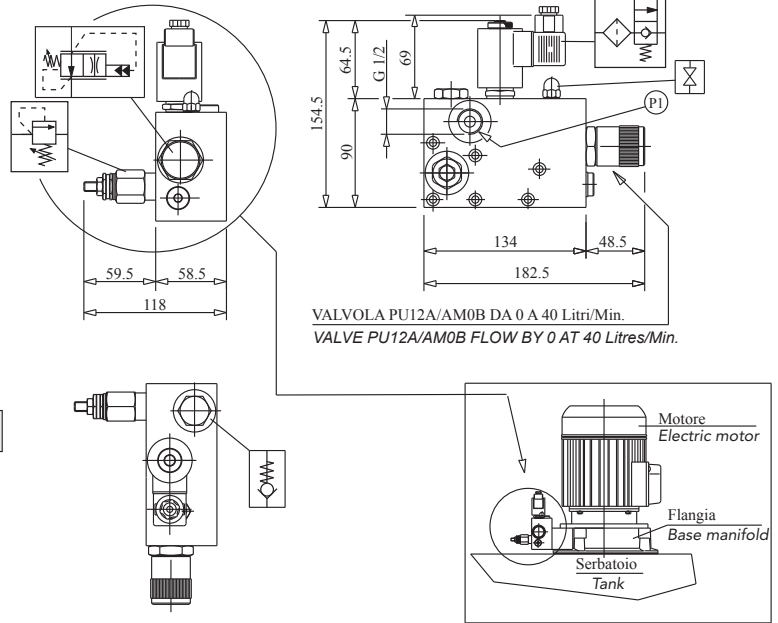

BLOCCHETTO BASE

BASE BLOCK

Schema oleodinamico
Hydraulic circuit

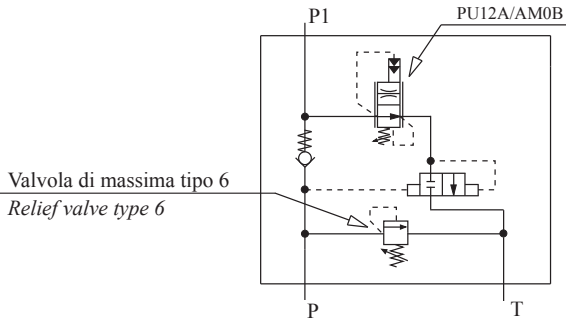

Codice ordinazione
Ordering code

S 1 5 5 - N 1 8 3

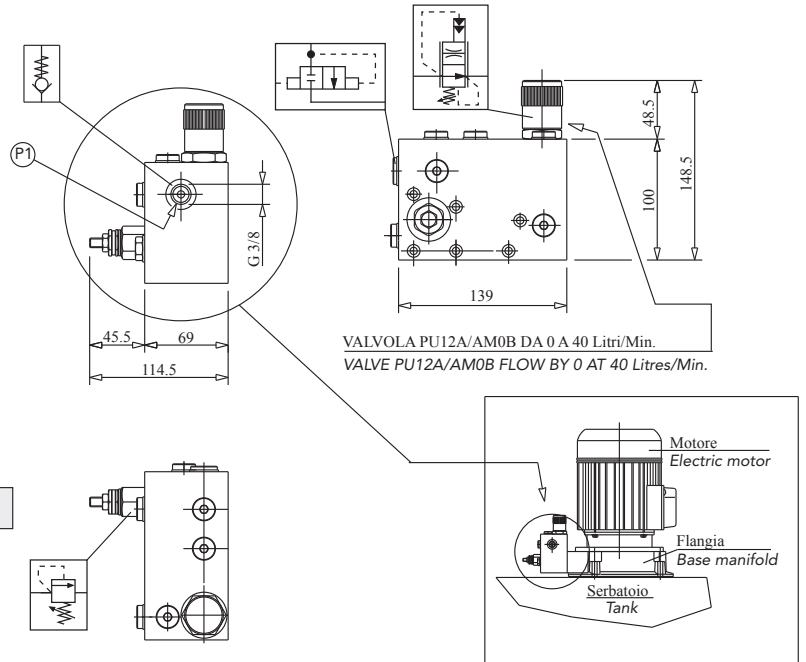

BLOCCHETTO BASE

BASE BLOCK

Schema oleodinamico
Hydraulic circuit

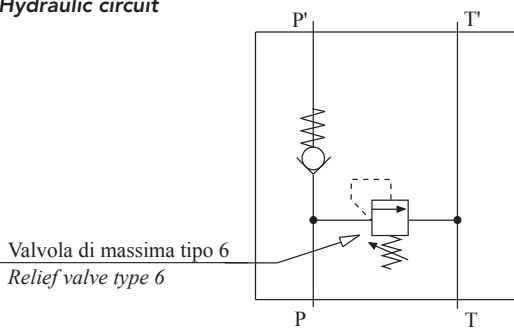

Codice ordinazione
Ordering code

S 1 5 4 - N 1 8 2

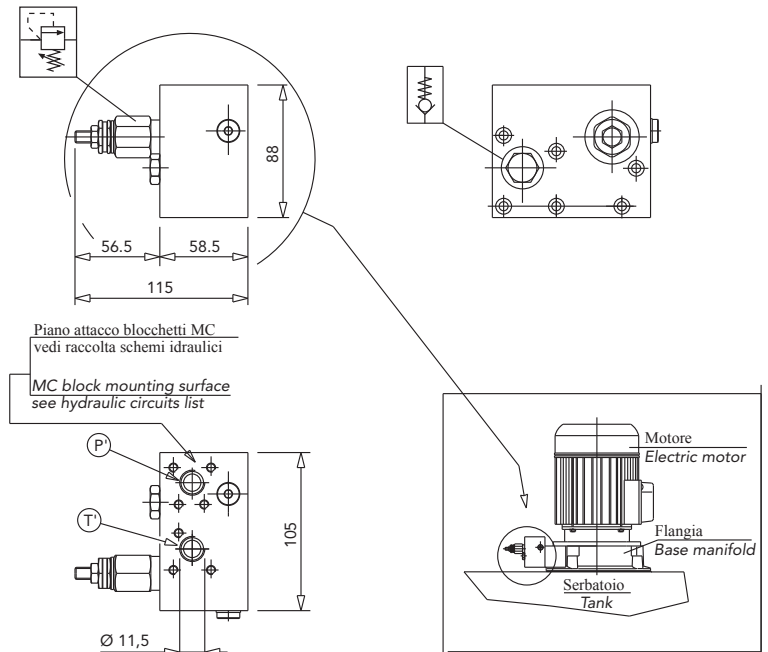

BLOCCHETTO BASE

B

BASE BLOCK

Schema oleodinamico
Hydraulic circuit

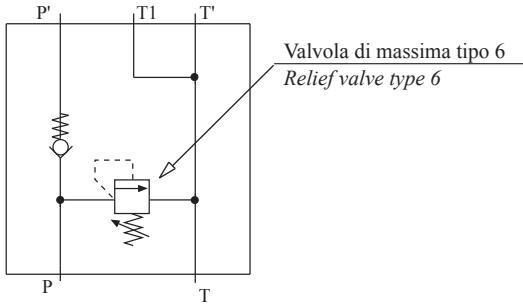

Codice ordinazione
Ordering code S 2 0 7 / 1 - N 2 5 9

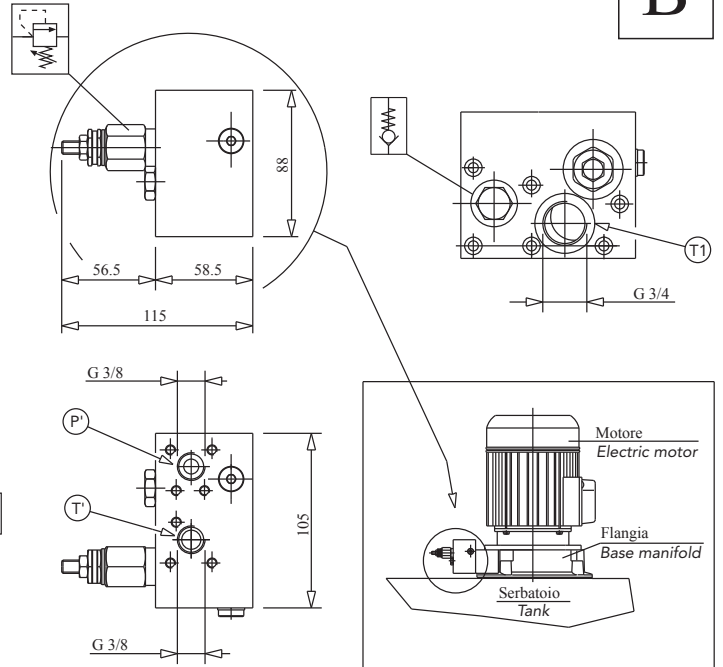

BLOCCHETTO BASE

BASE BLOCK

Schema oleodinamico
Hydraulic circuit

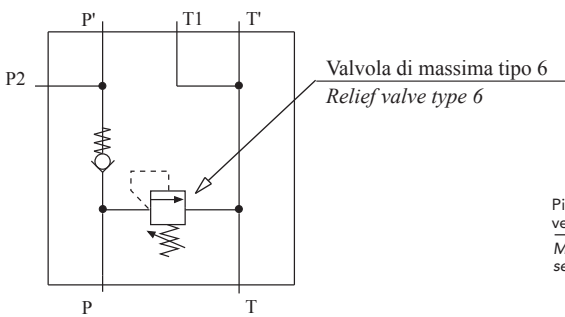

Codice ordinazione
Ordering code S 2 0 7 - N 3 0 2

Piano attacco blocchetti MC
vedi raccolta schemi idraulici
MC block mounting surface
see hydraulic circuits list

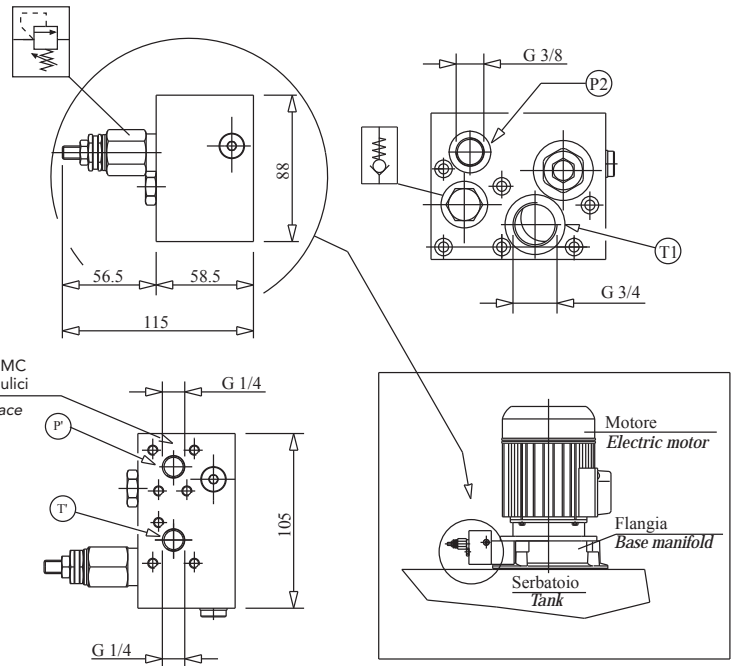

BLOCCHETTO BASE

BASE BLOCK

Schema oleodinamico
Hydraulic circuit

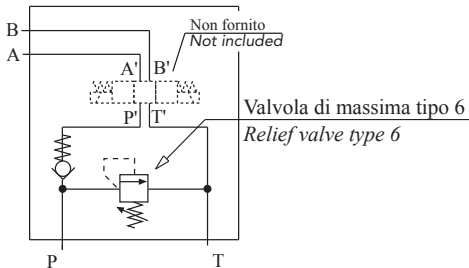

Codice ordinazione
Ordering code S 1 5 3 - N 1 9 5

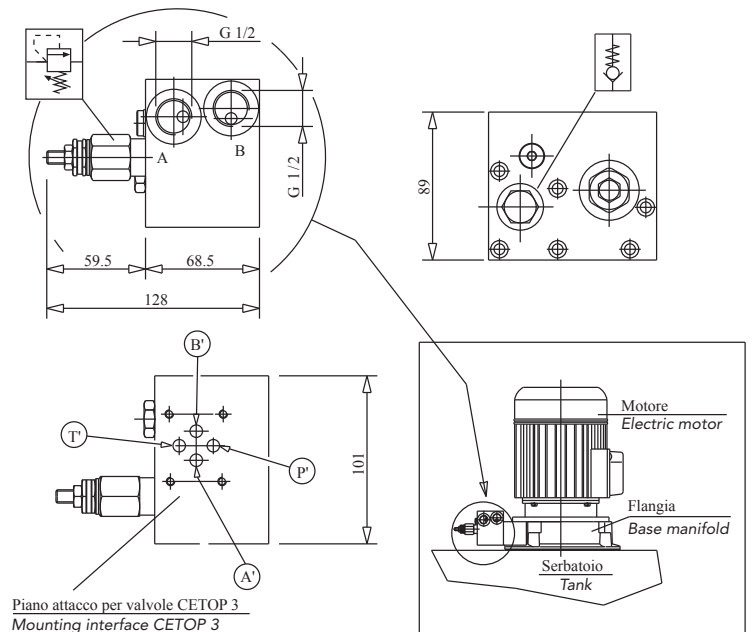

BLOCCHETTO BASE
BASE BLOCK

B

Schema oleodinamico
Hydraulic circuit

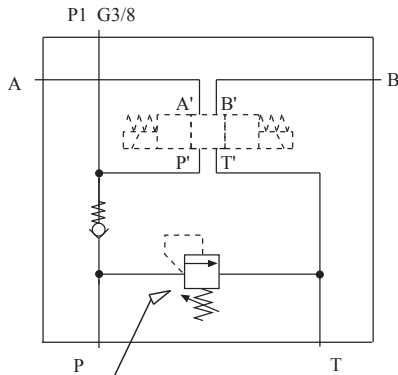

Valvola di massima tipo 6
Relief valve type 6

Codice ordinazione
Ordering code

S 1 6 6 - N 3 1 3

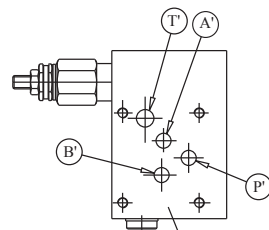
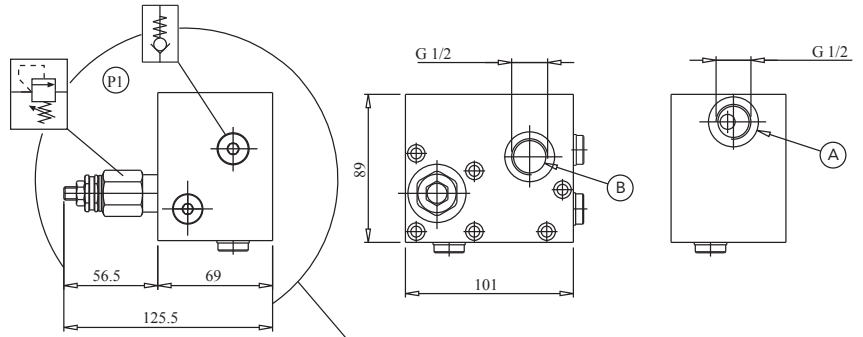

Piano attacco per valvole CETOP 5
Mounting interface CETOP 5

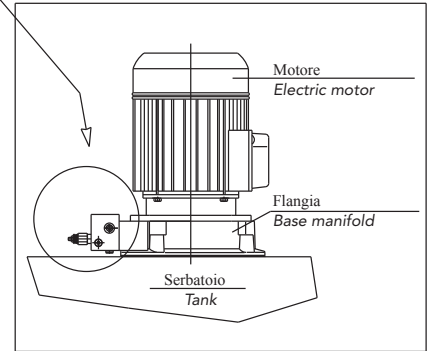

BLOCCHETTO BASE
BASE BLOCK

Schema oleodinamico
Hydraulic circuit

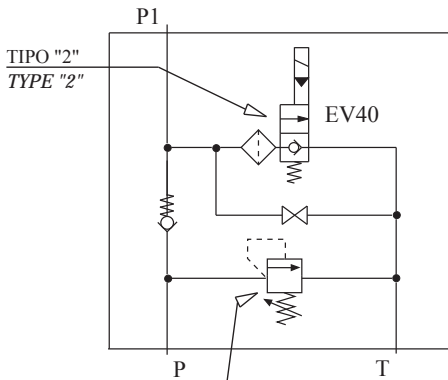

Valvola di massima tipo 6
Relief valve type 6

Codice ordinazione
Ordering code

S 2 0 3 / 4 - N 2 5 3

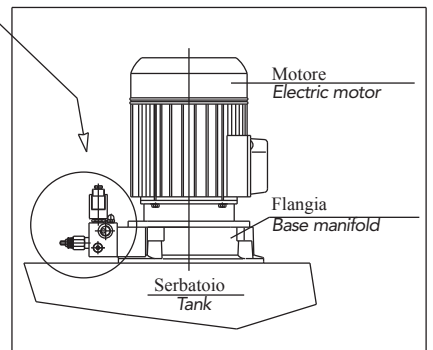
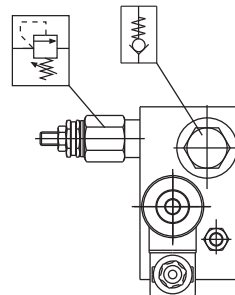
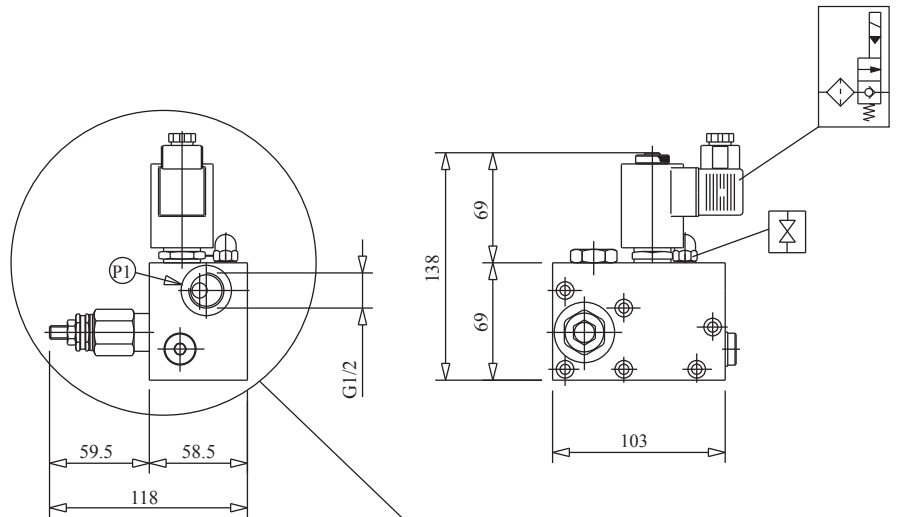

BLOCCHETTO MODULARE

STACKABLE

B

Schema oleodinamico
Hydraulic circuit

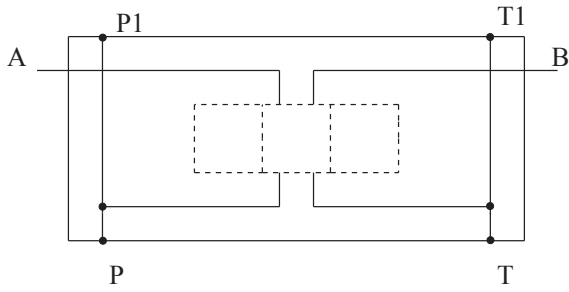

Codice ordinazione
Ordering code S 0 0 1 - N 1 6 3

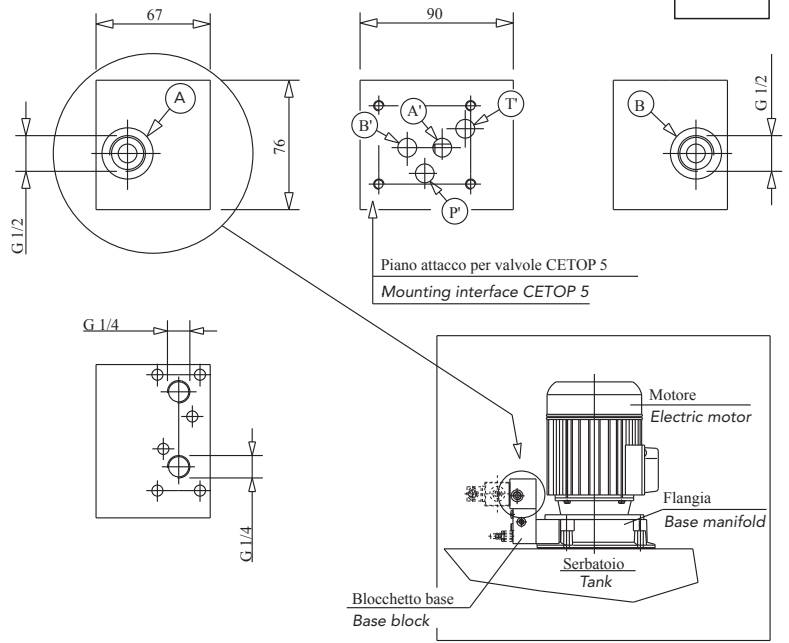

BLOCCHETTO BASE

BASE BLOCK

Schema oleodinamico
Hydraulic circuit

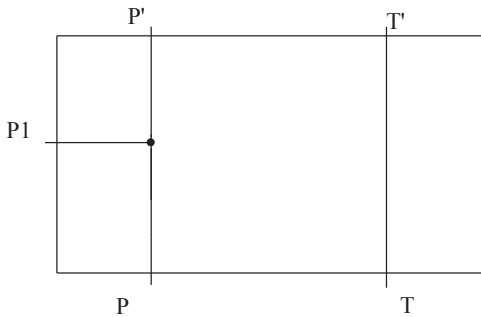

Codice ordinazione
Ordering code S 0 8 7 - N 2 2 2

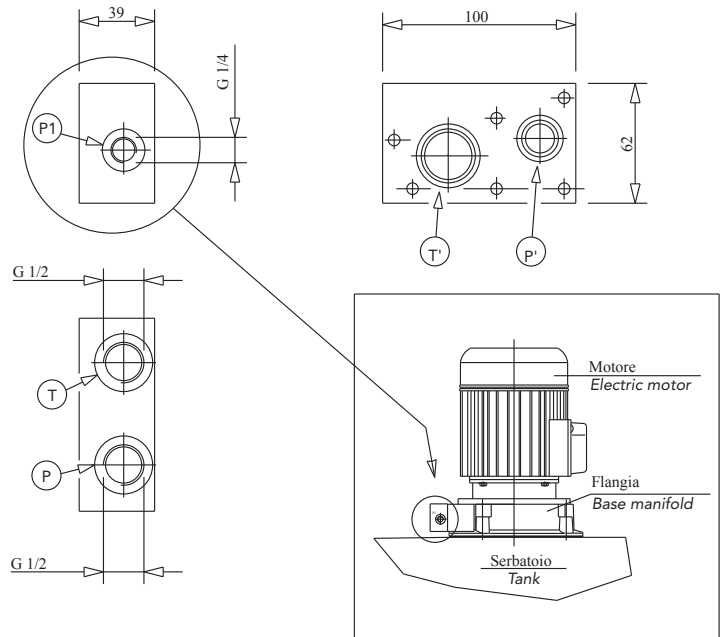

BLOCCHETTO BASE

BASE BLOCK

Schema oleodinamico
Hydraulic circuit

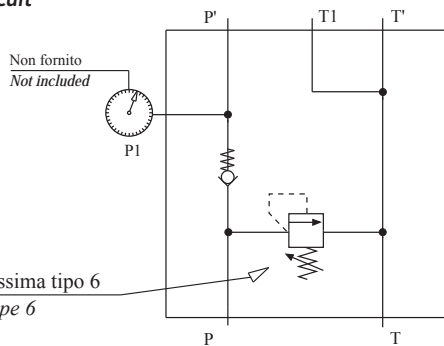

Codice ordinazione
Ordering code S 2 0 7 - N 2 5 9

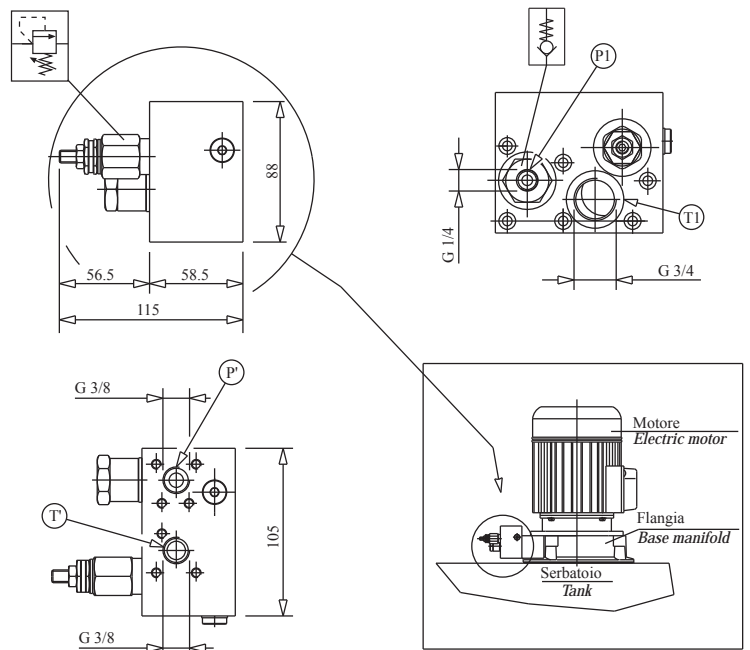

BLOCK MOUNTING INTERFACE

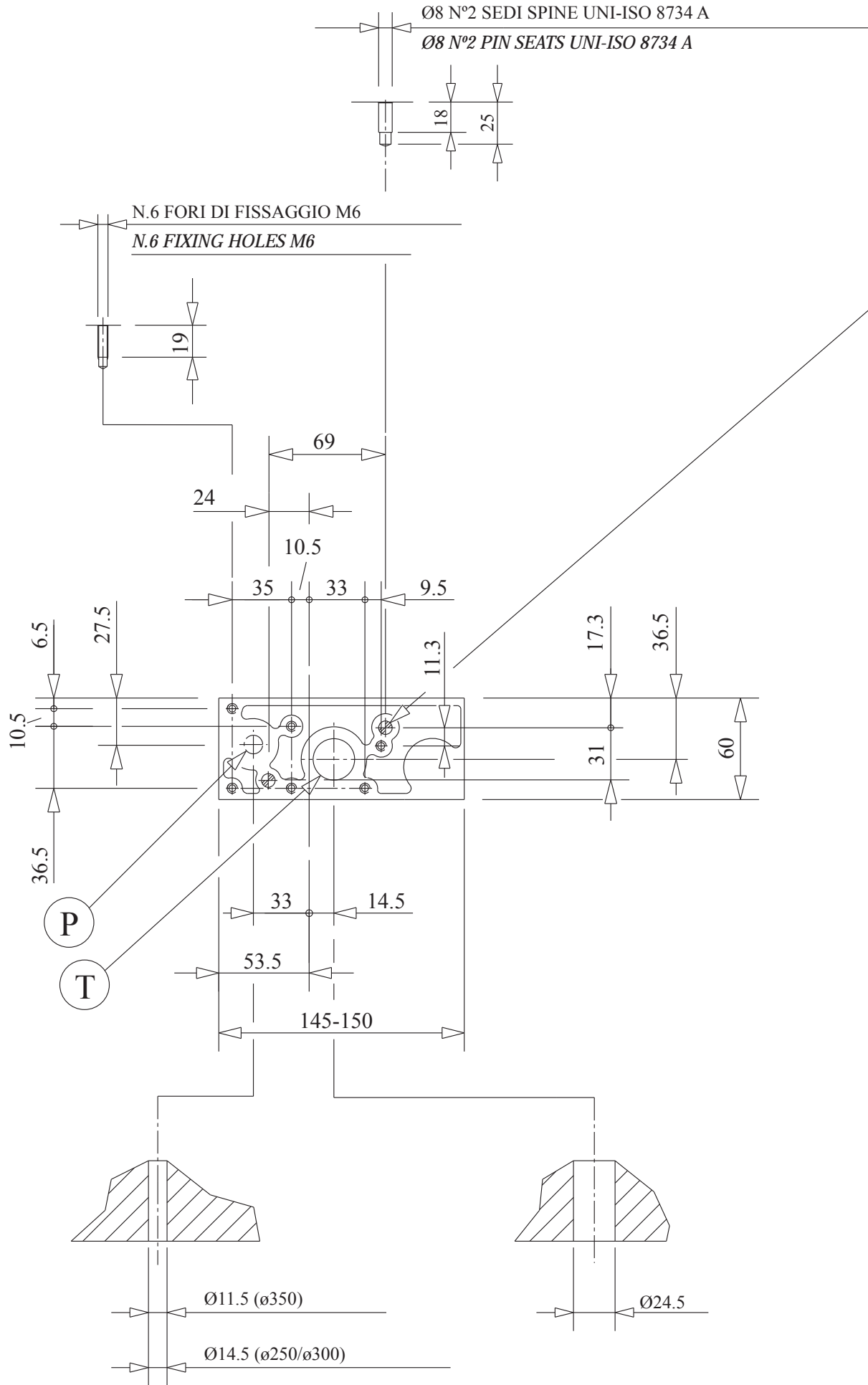

PER CAVITA' 1J
 FOR CAVITY 1J

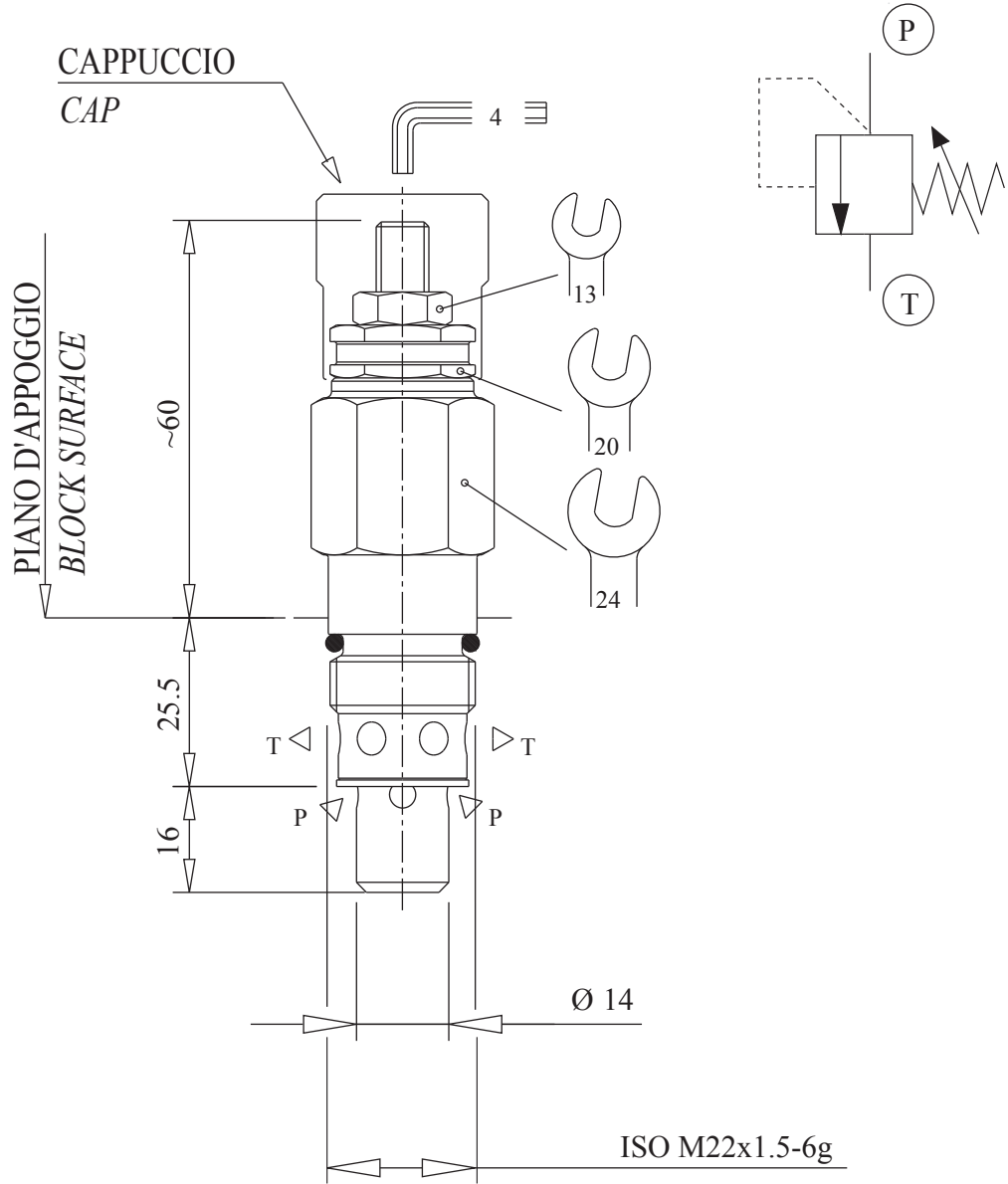

— V  —

D	0 ÷ 40 bar
E	20 ÷ 110 bar
F	50 ÷ 220 bar
G	150 ÷ 310 bar

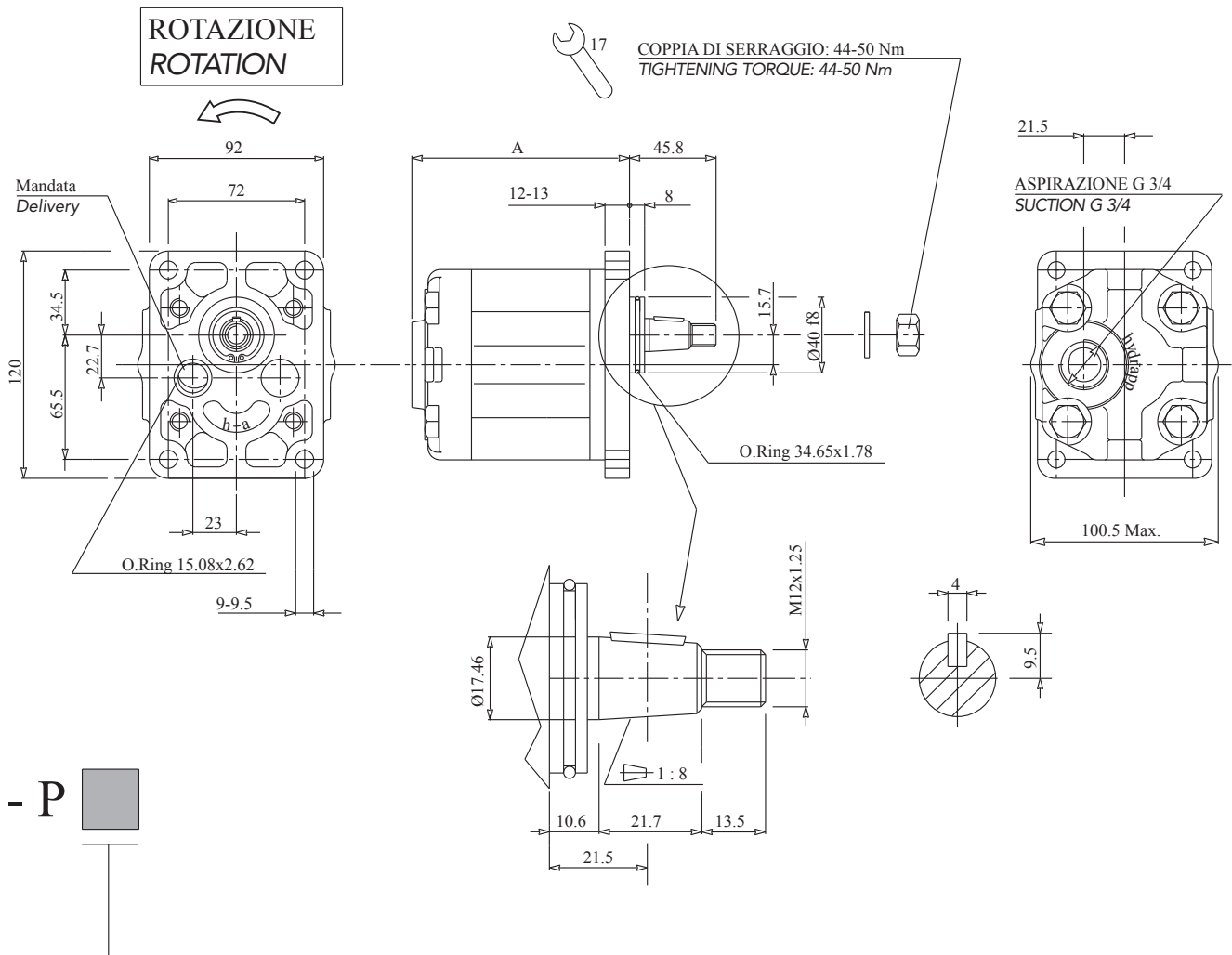

- P

CODICE DI ORDINAZIONE CILINDRATA POMPA	CILINDRATA NOMINALE	PRESSIONE MASSIMA CONTINUA	PRESSIONE DI PICCO *	ROTAZIONE ALBERO	DIMENSIONI
ORDERING CODE	NOMINAL DISPLACEMENT (cc/rev)	MAX. CONTINUOUS PRESSURE (bar)	OVERSHOOT PRESSURE* (bar)	ROTATION	DIMENSIONS A (mm)
G	4	230	250	SINISTRA LEFT	103
H	6	230	250		106.5
I	8	230	250		110.5
L	11	230	250		114.5
M	14	230	250		120.5
N	17	230	250		124.5
O	19	210	230		128.5
P	22	180	200		134.5
Q	25	160	175	138.5	

DATI TECNICI:

Fluido idraulico: normalmente impiegare un fluido idraulico a base minerale tipo HL, HLP (HM-ISO), HV secondo DIN 51524.
 Temperatura del fluido minima: -15°C
 Temperatura del fluido massima: 80°C
 Viscosità minima: 12cSt
 Viscosità massima all'avviamento: 1000 cSt
 Viscosità ottimale: 20-50 cST
 Livello di contaminazione: 18/14 ISO 4406

NOTE: * Per pressione di picco si intende il massimo valore di pressione di apertura della valvola di massima.

TECHNICAL DATA:

Type of fluid: mineral oil HL, HLP (HM-ISO), HV as DIN 51524.
 Oil temperature
 min.: -15°C
 max.: +80°C
Viscosity
 min.: 12 cSt.
 max.at the start: 1000 cSt.
 optimum: 20-50 cSt.
 Contamination level
 18/14 ISO 4406

NOTE: * The overshoot pressure is intended as the maximum pressure relief valve opening.

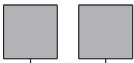
M 

ORIENTAMENTO MORSETTERIA RISPETTO "P-T" *
TERMINAL BOARD POSITION RESPECT TO "P-T" *

POSIZIONE DI MONTAGGIO
OMETTERE IN CASO DI ORDINE SENZA MOTORE
MOUNTING POSITION
TO LEAVE OUT IN CASE OF ORDER WITHOUT MOTOR.

CON QUESTO CODICE SI IDENTIFICA
LA DIMENSIONE DELLA FLANGIA MOTORE.

WITH THIS CODE WE IDENTIFY
THE MOTOR FLANGE DIMENSION.

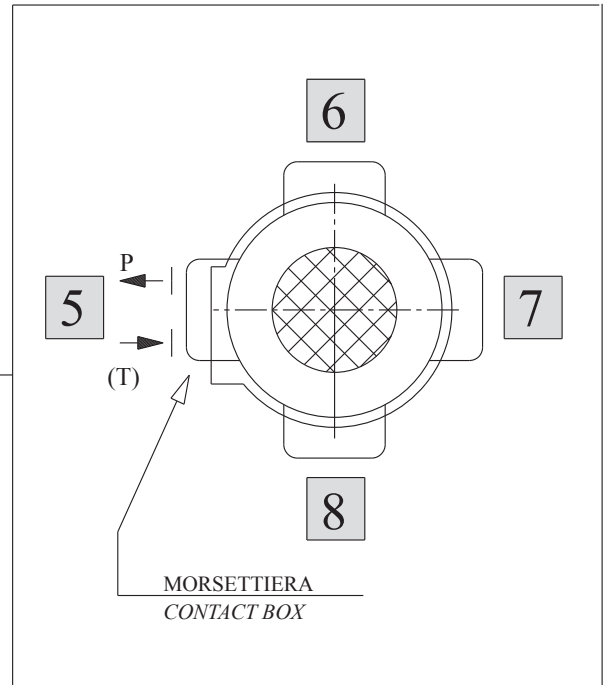

* Verificare contemporaneamente posizionamento "P-T" rispetto al serbatoio - pagina 12
Check in the same time the "P-T" position respect to the tank (page 12)

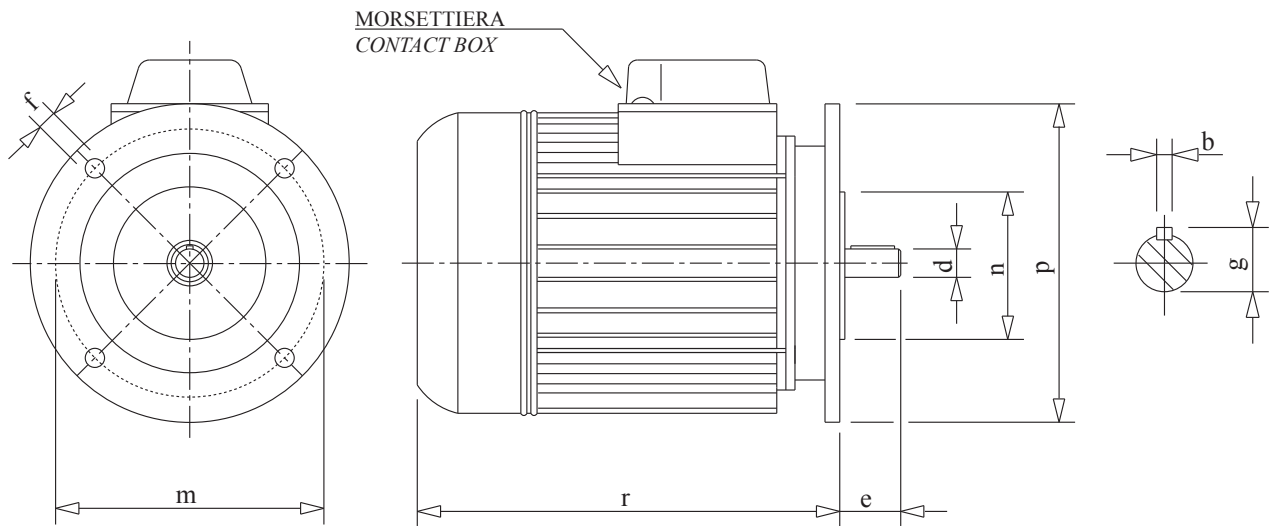

CODICE DI ORDINAZIONE ORDERING CODE	GRANDEZZA FRAME SIZE	N° POLI N° POLES	POTENZA(kW) POWER	b	d	e	f	g	m	n	p	r
A	100/112	2	3/4	8	28	60	14	31	215	180	250	301
		4	2.2/4									
		6	1.5/2.2									
B	132	2	5.5/7.5	10	38	80	14	41	265	230	300	416
		4	5.5/7.5									
		6	3/4/5.5									
C	160	2	11/15/18.5	12	42	110	18	45	300	250	350	540
		4	11/15									
		6	7.5/11									
D	180	2	22	14	48	110	18	51.5	300	250	350	580
		4	18.5/22									
		6	15									

DIMENSIONI FLANGIA Ø 250

BASE MANIFOLD 250 DIAMETER

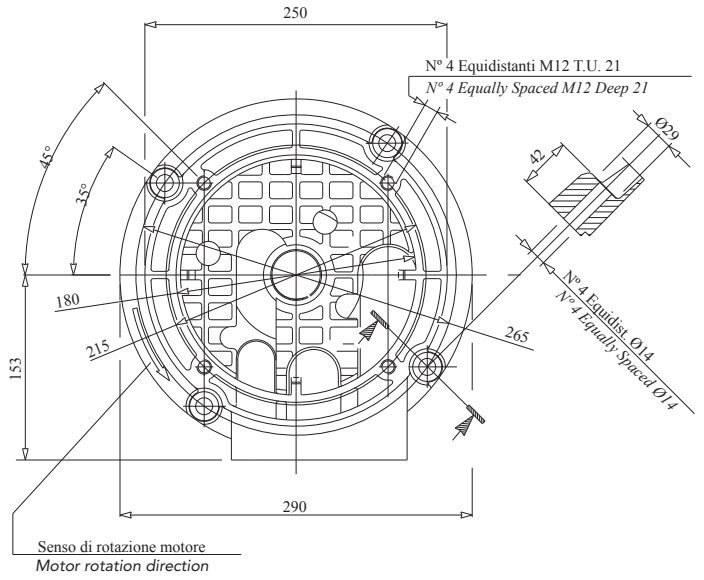
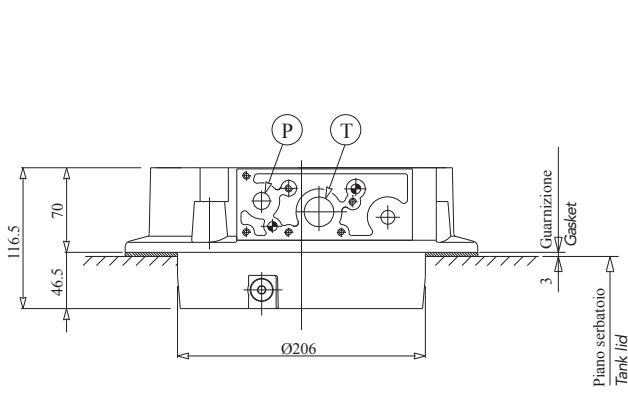

DIMENSIONI FLANGIA Ø 300

BASE MANIFOLD 300 DIAMETER

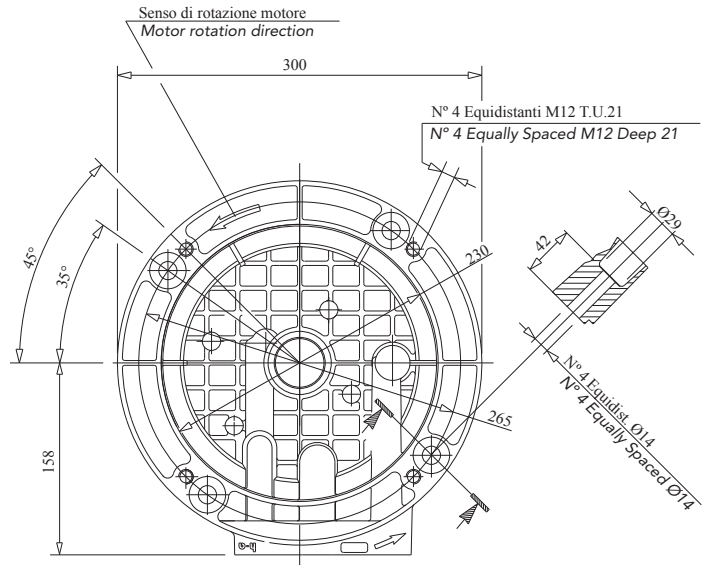
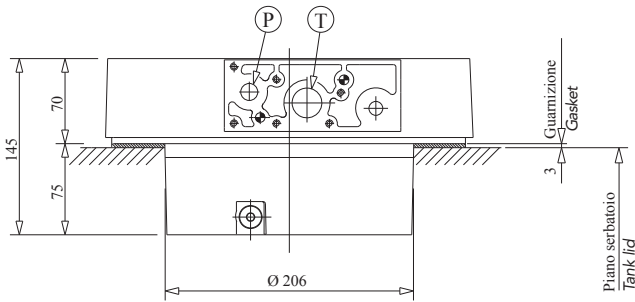

DIMENSIONI FLANGIA Ø 350

BASE MANIFOLD 350 DIAMETER

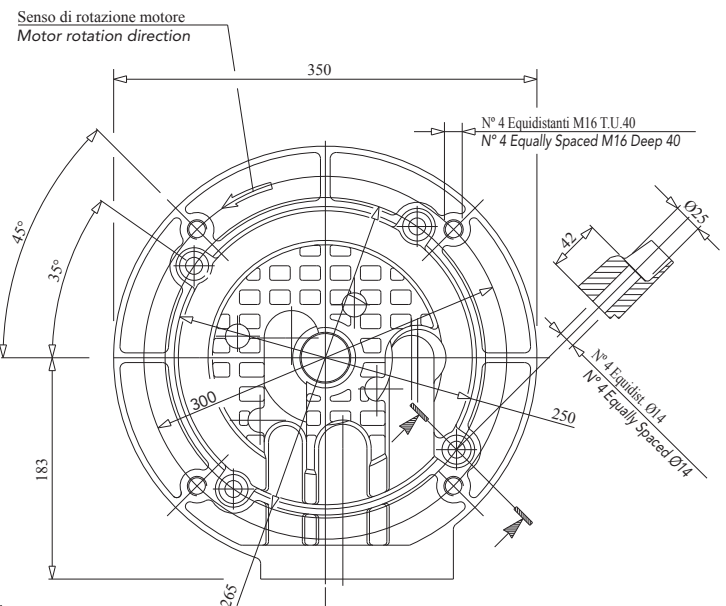
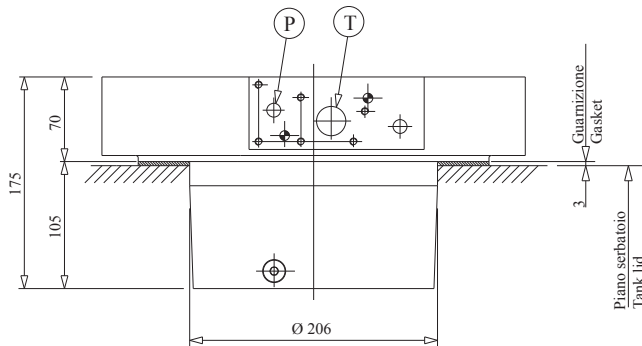

SERBATOI STANDARD

STANDARD TANKS

G

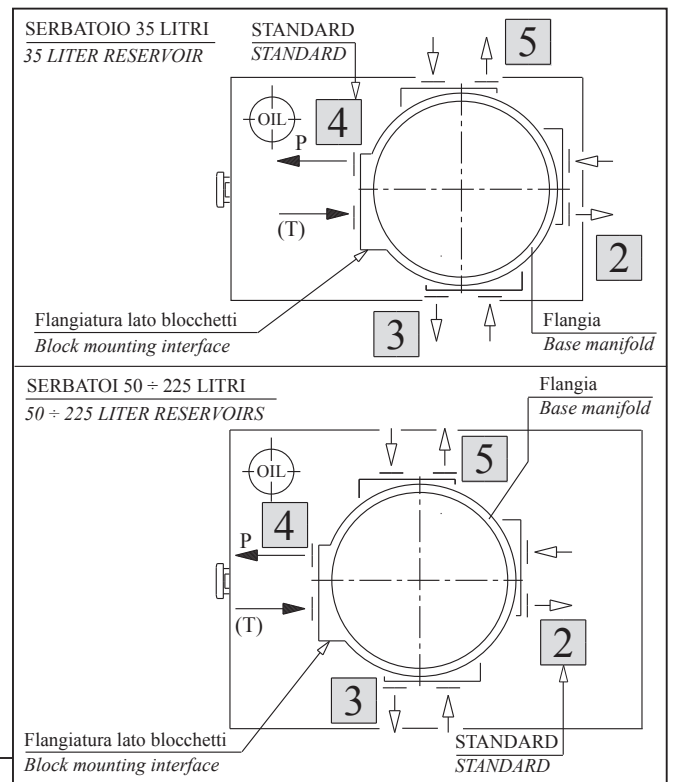
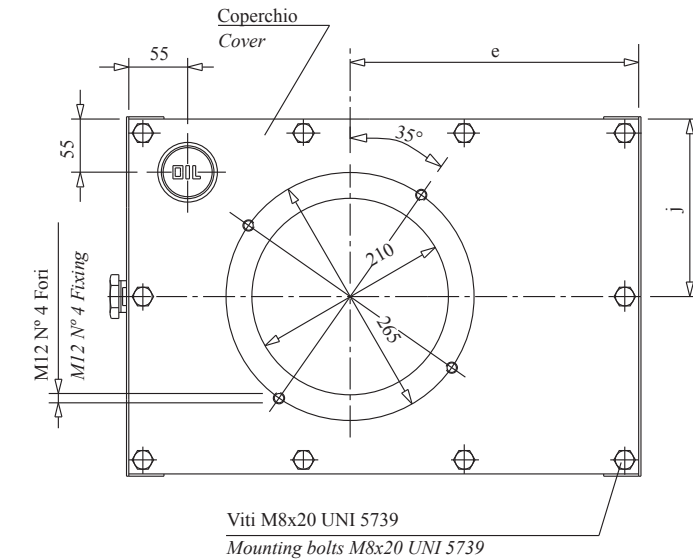
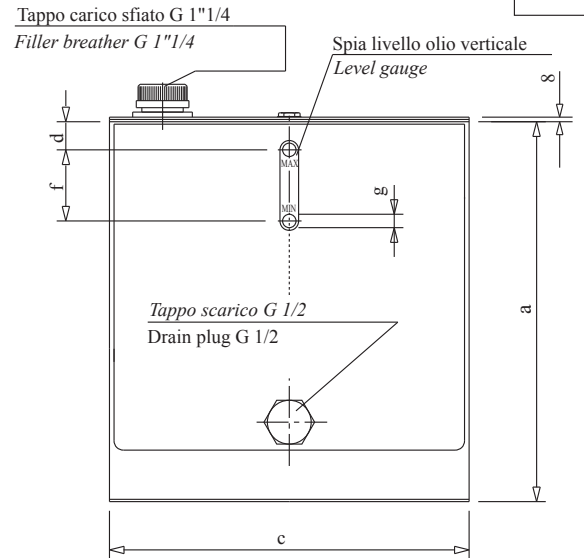
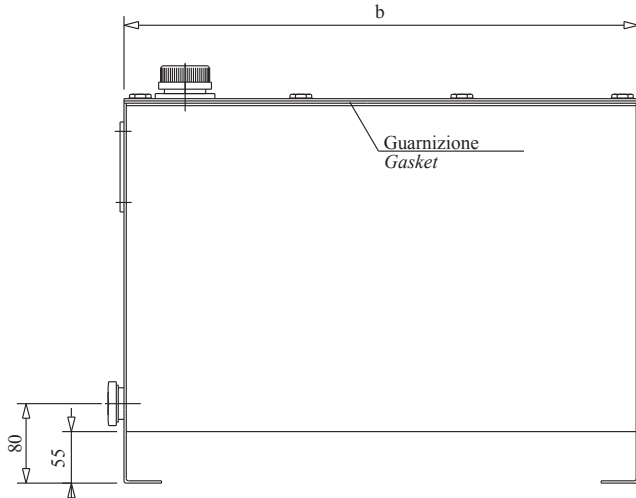

Senza serbatoio e senza kit tubi - Omettere
Without reservoirs and without hoses kits - To leave out

-T - F 0 Senza serbatoio
Without reservoirs

CAPACITA' LITRI NOMINAL CAPACITY LITRES	CODICE DI ORDINAZIONE ORDERING CODE	a	b	c	d	e	f	g	j
35	A	400	470	300	30	160	76	M10	147.5
50	B	420	500	400	30	275	76	M10	197.5
60	C	445	550	400	30	295	76	M10	197.5
75	D	530	550	400	50	295	76	M10	197.5
100	E	530	700	400	50	445	127	M12	197.5
150	F	620	750	500	80	492	127	M12	241.5
225	G	650	900	600	100	645	127	M12	220

Senza serbatoio senza coperchio
ma con kit tubi
Without reservoirs and without
covers, but with hoses kits

Scegliere riferimento in base
alla quota "a" del proprio serbatoio
Choose the reference basing on
"a" dimension of your tank

Esempio:
T D C kit tubi per serbatoio lt 75
Example:
T D C hoses kit for lt 75 tank

Hydr-app S.p.A. - Via Moscova, 6 - Villaggio Crostolo - 42020 Reggio Emilia
Tel. +39-0522-270711 - Fax +39-0522-270670
www.hydr-app.com - E-mail: salesdept@hydr-app.com

Hydr-App Lombardia S.r.l. - Via San Fiorano, 54/a - 20058 Villasanta (Milano)
Tel. +39-039-2052297 - Fax +39-039-2056126 - E-mail: vendite@hydr-app.lombardia.it

Hydr-App UK - Planet house, Centre Park - WARRINGTON, CHESHIRE WA1 1 QX
Phone 0044-1925-624800 - Fax 0044-1925-624801
www.hydr-app.com - E-mail: salesdept@hydr-app.com

Hydr-app GmbH Hydrauliksysteme - Benzstraße 7 - D-82291 Mammendorf
Tel. +49/8145/9283-0 - Fax +49/8145/9283-20
www.hydr-app.de - E-mail: info@hydr-app.de

Beijing Haipu Hydraulic Equipments Co. Ltd.
No. 518, Lai Guang YingXi Lu, Chao Yang District - 100012 Beijing-China
Tel. +86-10-84919664 - Tel. +86-10-84919674 - Fax +86-10-84919684
E-mail: yingjie@netchina.com.cn